

AMERICA "609"



BUILDING INSTRUCTION

This model is Copyright protected.
All Copyrights to this version of the America
belongs to KREAN Holding Aps.



www.billingboats.com

DK

609 AmericaA

1850 På baggrund af en stort ønske fra New York Yacht Club om at bygge et hurtigt sejlskib, lavede George Steers planerne til AmericaA. Denne lave sorte skonnert er designet ved omvendt brug af "cod-head-and-mackerel-tail" type.

1851 Som svar på en udfordring fra the Royal Yacht Squadron, deltager skonnerten AmericaA i Hundred Guinea Cup racet, en 53-mil sejlads rundt om Isle of Wright. Den vinder nemt over de 14 britiske skibe og modtager Hundred Guinea Cup trofæet. Den 25. august, besøger selveste Dronning Victoria skibet. AmericaA vender stolt hjem og fremviser prisen til New York Yacht Club, som derefter omdøbes til America's Cup.

1863 I de næste 12 år, havde AmericaA en del forskellige ejere på begge sider af Atlanten. I 1863 vender skonnerten hjem til Newport, Rhode Island for at fungere som træningsskib for United States Naval Academy.

1870 AmericaA deltager i America's Cup og ender som nr. 4 ud af 15 deltagere.

1901 AmericaA deltager i hendes nr. 51 og sidste race. I de næste 15 år ligger hun under et dækket i Boston.

1921 Efter år med forskellige ejere, vender AmericaA igen tilbage til Naval Academy i Annapolis, Maryland, hvor hun bliver behandlet dårligt.

1940 AmericaA, som allerede er i forfald, er efterladt til rådne op i et skur i Annapolis Yacht Yard under anden Verdenskrig. Præsident Roosevelt presser kongressen til at afsætte \$ 100.000 for at sende AmericaA til National Naval Museum. Desværre får krigen første prioritet. I 1942, under en heftig snestorm, falder taget på skuret sammen og det rådne træ giver efter. Det træ som kunne bjerges blev brugt til at bygge en model af skibet, som nu står i Naval Academy Museum.

GB

609 AmericaA

1850 - On the urging of the New York Yacht Club to build a fast sailing boat, George Steers creates plans for the AmericaA. The low black schooner is designed using the reversal of the "cod-head-and-mackerel-tail style."

1851 - Answering a challenge from the Royal Yacht Squadron, the schooner AmericaA enters the Hundred Guinea Cup race, a 53-mile race around the Isle of Wight. It easily defeats the 14 British ships and is awarded the Hundred Guinea Cup. On August 25, Queen Victoria herself visits the ship. AmericaA returns home and presents the New York Yacht Club with its prize, which is renamed America's Cup.

1863 - For the next 12 years, the AmericaA had a number of owners on both sides of the Atlantic. In 1863, the schooner returns to Newport, Rhode Island to serve as a training ship for the United States Naval Academy.

1870 - The AmericaA races in the America's Cup where it finishes fourth of 15 entries.

1901 - The AmericaA sails in her 51st, and last race. For the next 15 years she will lay under cover in Boston.

1921 - After years of different owners, the AmericaA is once again returned to the Naval Academy in Annapolis, Maryland, where she is poorly maintained.

1940 - The AmericaA, already decaying, is left to rot in a shed in the Annapolis Yacht Yard during World War II. President Roosevelt pressures Congress to appropriate \$100,000 to turn the AmericaA into the National Naval Museum. Unfortunately, the war takes priority. In 1942, under heavy snow, the roof of the shed collapses and the heavily rotted wood gives way. What wood was salvageable is used to make a model of the ship, which is at the Naval Academy museum.

D

609 AmericA

1850 - Auf das Drängen des New Yorker Yacht Clubs hin, ein schnelles Segelboot zu bauen, entwickelte George Steers 1850 die AmericA. Der tiefe schwarze Schoner ist das genaue Gegenteil des „Dorsch-Bug und Makrelen-Heck“ Design.

1851 - Einer Einladung des Royal Yacht Squadron folgend nimmt der Schoner AmericA 1851 am Hundred Guinea Cup teil, einem 53 Meilen Rennen rund um die Isle of Wight (Ärmelkanal). Mit Leichtigkeit setzt sich das Schiff gegen die 14 britischen Konkurrenten durch und gewinnt den Cup. Am 25 August 1851 besichtigt Königin Viktoria persönlich das Boot. Danach kehrt die AmericA mit dem Preis, der von dann ab „America's Cup“ heißt, nach Hause zum New Yorker Yacht Club zurück.

1863 - In den folgenden 12 Jahren hat die AmericA verschiedene Besitzer auf beiden Seiten des Atlantik. Im Jahr 1863 kehrt der Schoner nach Newport, Road Island zurück, wo er dann als Schulschiff der United States Naval Academy dient.

1870 - trat die AmericA noch einmal im America's Cup an, wo Sie als viertes Schiff von 15 teilnehmenden Schiffen ins Ziel einlief. 1901 bestreitet die AmericA ihr 51zigstes und letztes Rennen.

1901 - In den folgenden 15 Jahren liegt das Schiff mit Planen gegen Wind und Wetter notdürftig abgedeckt in Boston.

1921 - Nach Jahren mit unterschiedlichsten Besitzern kehrt die AmericA 1921 an die Naval Academy, diesmal in Annapolis, Maryland zurück, wo sie jedoch sehr vernachlässigt wird.

1940 - Während des zweiten Weltkrieges, im Jahr 1940 wird die bereits verfallende AmericA in einer Bootshütte im Yachthafen von Annapolis abgestellt. Präsident Roosevelt drängt den Kongress für den Umzug der AmericA in das nationale Schifffahrtsmuseum 100.000\$ zur Verfügung zu stellen. Unglücklicherweise hatte der Krieg höhere Priorität, wodurch dieser Plan fallen gelassen wurde. Im Winter 1942 bracht dann das Dach der Bootshütte unter dem Gewicht gefallenen Schnees zusammen und das modrige Holz der AmericA gab nach. Das wenige rettenswerte Holz wird geborgen, um daraus ein Modell der AmericA zu bauen, welches heute noch in dem Museum der Naval Academy steht.

F

609 AmericA

1850 - Suite à la demande urgente du New York Yacht Club de construction d'un voilier rapide, George Steers crée les plans de l'AmericA.

1851 - Pour répondre au défi du Royal Yacht Squadron, la goélette AmericA est engagée dans la course " Hundred Guinea Cup race", une course de 53 miles autour de l'île de Wight. Elle bat facilement le bateau anglais et remporte la coupe. Le 25 août, la reine Victoria visite le bateau. L'America rentre au New York Yacht Club et la coupe sera renommée "Coupe de l'America".

1863 - Dans les 12 ans qui suivront, l'AmericA appartiendra à différents propriétaires des 2 côtés de l'Atlantique. En 1863, la goélette retourne à Newport, Rhode Island, pour servir de bateau d'entraînement pour l'United States Naval Academy.

En 1870 , - l'AmericA participe à la coupe de l'AmericA et finit 4eme sur 15 engagés.

En 1901,- l'AmericA participe à sa 51eme et dernière course. Durant les 15 ans qui suivirent, elle fut conservée à Boston.

En 1921 - après des années passées aux mains de différents propriétaires, l'AmericA retourne à la "Naval Academy" à Annapolis dans le Maryland, ou elle est pauvrement entretenue.

En 1940,- l'AmericA, déjà en mauvais état est entreposée dans un hangar du "Annapolis Yacht Yard" durant toute la seconde guerre mondiale. Le Président Roosevelt fit pression sur le congrès pour que la somme de 100 000 dollars soit attribuée à l'AmericA pour la restaurer et l'exposer au "National Naval Museum". Malheureusement la guerre était prioritaire. En 1942 d'importantes chutes de neige occasionnent des dégâts importants. Les parties restantes furent utilisées pour faire une reproduction du bateau, exposée au "National Naval Museum".

609 AmericaA

1850 - Op aandringen van de New York Yacht Club om een snelle zeilboot te bouwen, ontwierp George Steers de plannen voor de AmericaA. Deze slanke zwarte schoener is ontworpen in de omgekeerde “kabeljouwkop-en-makreel-staart” stijl.

1851 - In antwoord op de uitdaging van de Royal Yacht Club doet de AmericaA mee aan de Hundred Guinea Cup race, een wedstrijd over 53 mijl rond het eiland Wight. De 14 deelnemende Britse schepen worden eenvoudig verslagen en de AmericaA wint de Hundred Guinea Cup. Op 25 augustus wordt het schip bezocht door Koningin Victoria. De AmericaA vaart terug naar Amerika en presenteert de New York Yacht Club de Hundred Guinea Cup, die omgedoopt wordt in de America's Cup. Gedurende de volgende 12 jaar is de AmericaA in het bezit van verschillende eigenaren aan weerszijden van de Atlantische Oceaan.

1863 - De schoener keert terug naar Newport, Rhode Island om te gaan dienen als trainingsschip voor de Academie van de Amerikaanse Marine.

1870 - De AmericaA neemt deel aan de America's Cup waarin het als vierde van de vijftien deelnemers eindigt.

1901 - De AmericaA zeilt haar 51^{ste} en laatste race. De volgende 15 jaren ligt ze onder een dekzeil in Boston.

1921 - Na jaren van verschillen eigenaren keert de AmericaA weer terug naar de Academie van de Amerikaanse Marine in Annapolis, Maryland, waar ze slecht onderhouden wordt.

1940 - De AmericaA, al in zeer slechte staat, ligt te rotten in een loods van de Annapolis Yacht Yard tijdens de 2^e wereldoorlog. President Roosevelt dringt er bij het congres op aan om \$ 100.000 beschikbaar te stellen om de AmericaA als een Nationaal Scheepvaart Museum in te richten. Helaas, de oorlog heeft prioriteit. In 1942 bezwijkt het dak van de loods na hevige sneeuwval en het schip raakt zwaar beschadigd. Van het nog bruikbare hout wordt een model van het schip gemaakt dat nu in het museum van de Academie staat.

609 AmericaA

1850 A raíz del gran deseo del club de yates de Nueva York (New York Yacht Club) de construir una nave de gran velocidad, George Steers elaboró los bosquejos para la goleta America. Esta baja goleta negra fue diseñada haciendo un uso inverso del tipo de proa llena y popa estrecha (“cod-head-and-mackerel-tail”).

1851 Respondiendo a un reto del Royal Yacht Squadron, la goleta America participa en la regata Copa de las 100 Guineas (Hundred Guinea Cup), una carrera de 53 millas alrededor de la Isla de Wight. Aventaja con facilidad a las 14 naves británicas y se lleva el trofeo de la Copa de las 100 Guineas. El 25 de agosto la propia Reina Victoria de Inglaterra visita la nave. America regresa a casa con todos los honores y presenta al club de yates de Nueva York el premio, que en adelante se rebautiza con el nombre de la Copa América (America's Cup).

1863 Durante los 12 años siguientes, America tuvo diversos propietarios a ambos lados del Atlántico. En 1863 la goleta regresa a Newport, Rhode Island, para ser usada como nave escuela de la Academia Naval de los Estados Unidos (United States Naval Academy).

1870 America participa en la Copa América y de 15 participantes consigue quedar la cuarta.

1901 America participa en su última carrera, la número 51. Durante los 15 años siguientes está cubierta de mantas de cuadra en Boston.

1921 Tras años con diversos propietarios, America vuelve a la Academia Naval en Anápolis (Naval Academy in Annapolis), Maryland, donde no recibe un buen tratamiento.

1940 America, que ya se encuentra en ruinas, es abandonada para que se pudra en un cobertizo del astillero de yates de Annapolis (Annapolis Yacht Yard) durante la Segunda Guerra Mundial. El Presidente Roosevelt convence al Congreso de que destine \$ 100.000 a fin de trasladar America al Museo Naval Nacional (National Naval Museum). Desafortunadamente, se da primacía a la guerra. En 1942, durante una fuerte tormenta de nieve, se hunde el techo del cobertizo y la madera podrida cede. La madera que se pudo rescatar fue usada para construir un modelo de la nave, que actualmente se encuentra en el Museo de la Academia Naval (Naval Academy Museum).

I

609 America

1850 A seguito della richiesta del New York Yacht Club di costruire un'imbarcazione a vela veloce, George Steers inizia la progettazione dell'America. Questa goletta bassa di colore nero è progettata utilizzando un principio inverso di tipo a prua larga e poppa stretta ("cod-head-and-mackerel-tail").

1851 Accettando una sfida del Royal Yacht Squadron, la goletta America partecipa alla Coppa delle Cento Ghinee (Hundred Guinea Cup), una regata di 53 miglia attorno all'Isola di Wight. La vincerà facilmente, battendo le 14 imbarcazioni britanniche, e riceverà la Hundred Guinea Cup.

Il 25 agosto è la regina Vittoria in persona a far visita alla nave. L'America torna orgogliosamente in patria e mostra il premio al New York Yacht Club; premio che in seguito verrà ribattezzato Coppa America (America's Cup).

1863 Nei 12 anni successivi, l'America è passata attraverso numerosi proprietari su entrambi i lati dell'Atlantico. Nel 1863 la goletta torna a Newport, Rhode Island, per essere utilizzata come nave da esercitazione per l'Accademia Navale de Estados Unidos (United States Naval Academy).

1870 L'America partecipa all'America's Cup che concluderà al quarto posto su 15 partecipanti.

1901 L'America partecipa alla sua 51esima regata, che sarà anche l'ultima. Nei 15 anni successivi, la nave rimarrà attraccata sotto un telone a Boston.

1921 Dopo essere passata attraverso diversi proprietari, America torna nuovamente all'Accademia Navale di Annapolis (Naval Academy di Annapolis), Maryland, dove viene trattata malamente. 1940 L'America, ormai in disfacimento, viene lasciata marcire in un capannone di Annapolis Yacht Yard nel corso della seconda guerra mondiale. Il presidente Roosevelt fa pressione sul Congresso perché vengano stanziati \$ 100.000 per trasferire l'America al Museo Navale Nazionale (National Naval Museum). Ma sarà purtroppo la guerra ad avere la precedenza sul resto. Nel 1942, mentre imperversa una tempesta di neve, crolla il tetto del capannone ed il legno ormai marcio si sfascia. Il legno che si è potuto recuperare è stato utilizzato per costruire un modello della nave, che oggi si trova proprio al Museo dell'Accademia Navale (Naval Academy Museum).

P

609 America

1850 Devido ao grande desejo do Clube de lates de Nova Iorque (New York Yacht Club) de construir um veleiro rápido, George Steers fez os planos do America. Esta escuna baixa e negra foi projectada pelo inverso do tipo normal de proa estreita e popa larga ("cop-head-and-mackerel-tail").

1851 Em resposta a um desafio da Esquadra Real de lates (Royal Yacht Squadron), a escuna America participa na corrida da Taça de Cem Guinéus (Hundred Guinea Cup), uma regata de 53-milhas à volta da ilha de Wight. Ela vence facilmente os 14 navios ingleses e recebe o troféu da Taça de Cem Guinéus. Em 25 de Agosto a rainha Victoria, em pessoa, visita o navio. America regressa orgulhosa e mostra a taça ao Clube de lates de Nova Iorque, que a partir de então muda o nome para Taça da América (America's Cup).

1863 Nos doze anos que se seguiram, America teve vários donos de ambos os lados do Atlântico. Em 1863 a escuna regressa a Newport, Rhode Island, para servir de barco de treino da Academia Naval dos Estados Unidos (United States Naval Academy).

1870 America participa na Taça da América e termina em quarto lugar entre os quinze participantes.

1901 America participa na sua corrida n.º 51, que é a sua última. Nos quinze anos que se seguiram permaneceu em Boston, tapada com uma capa.

1921 Após um ano com diversos donos, America volta para a Academia Naval em Annapolis (Naval Academy em Annapolis), Maryland, onde é maltratada.

1940 America, já em ruínas, é abandonada a apodrecer num barracão no estaleiro de lates de Annapolis (Annapolis Yacht Yard) durante a Segunda Guerra Mundial. O presidente Roosevelt tenta compelir o Congresso a reservar 100.000 dólares para enviar America para o Museu Nacional de Marinha (National Naval Museum). Infelizmente, a guerra tem a maior prioridade. Em 1942, durante uma tempestade de neve, o telhado do barracão desabou e o casco podre cedeu. A madeira que pôde ser recuperada foi utilizada para construir um modelo do barco, que está agora no Museu da Academia Naval (Naval Academy Museum).

FIG.1

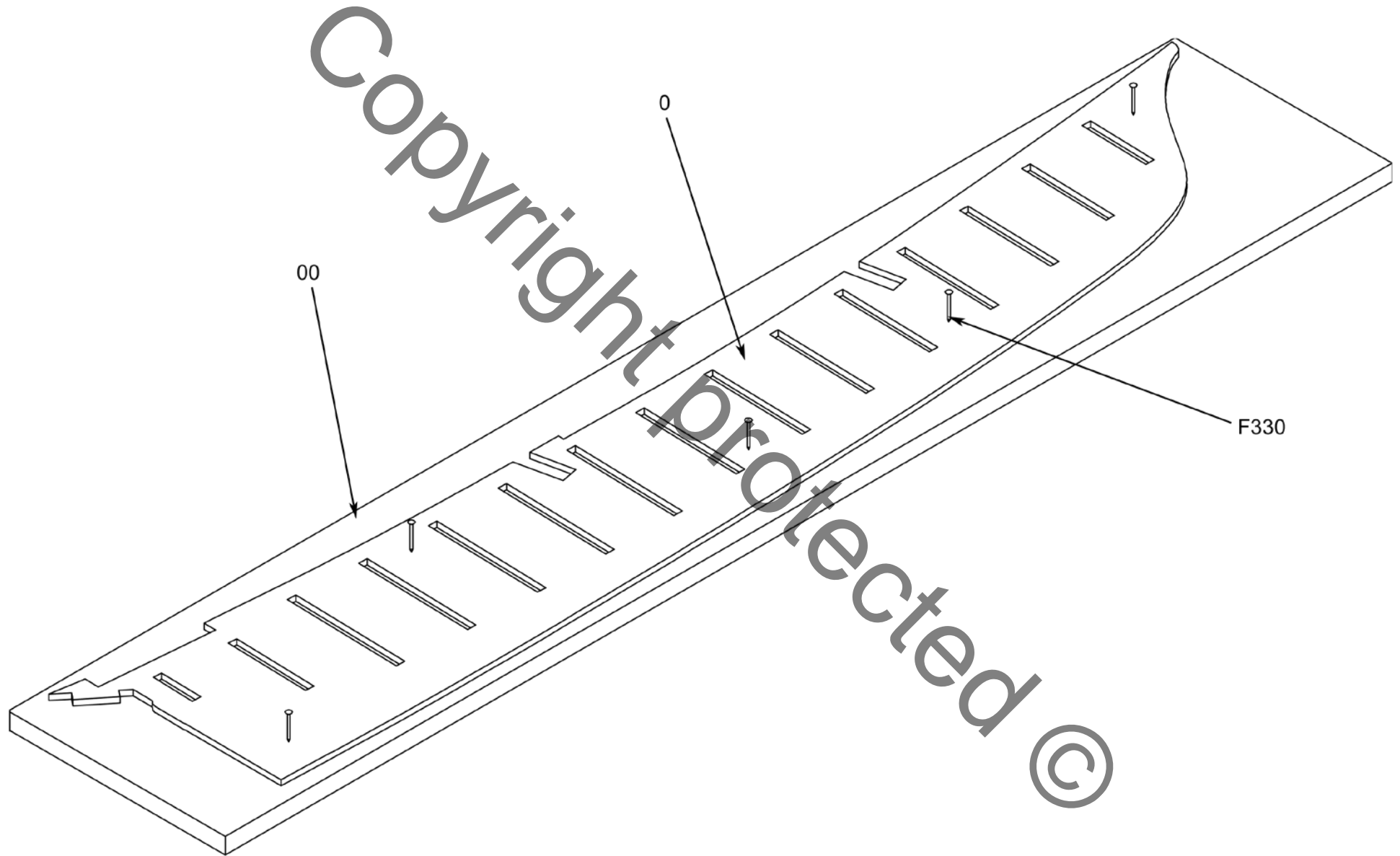

FIG.2

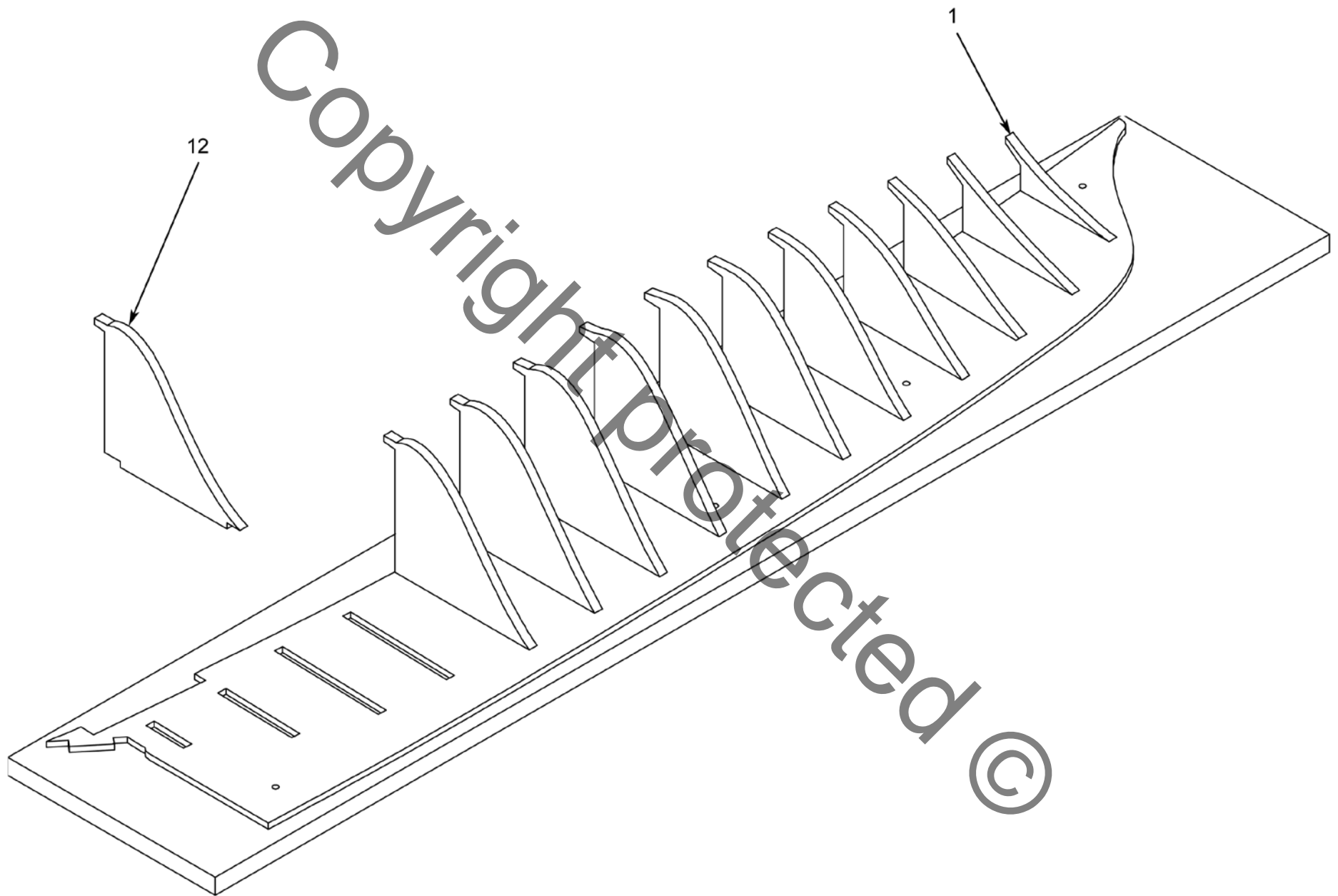

FIG.3

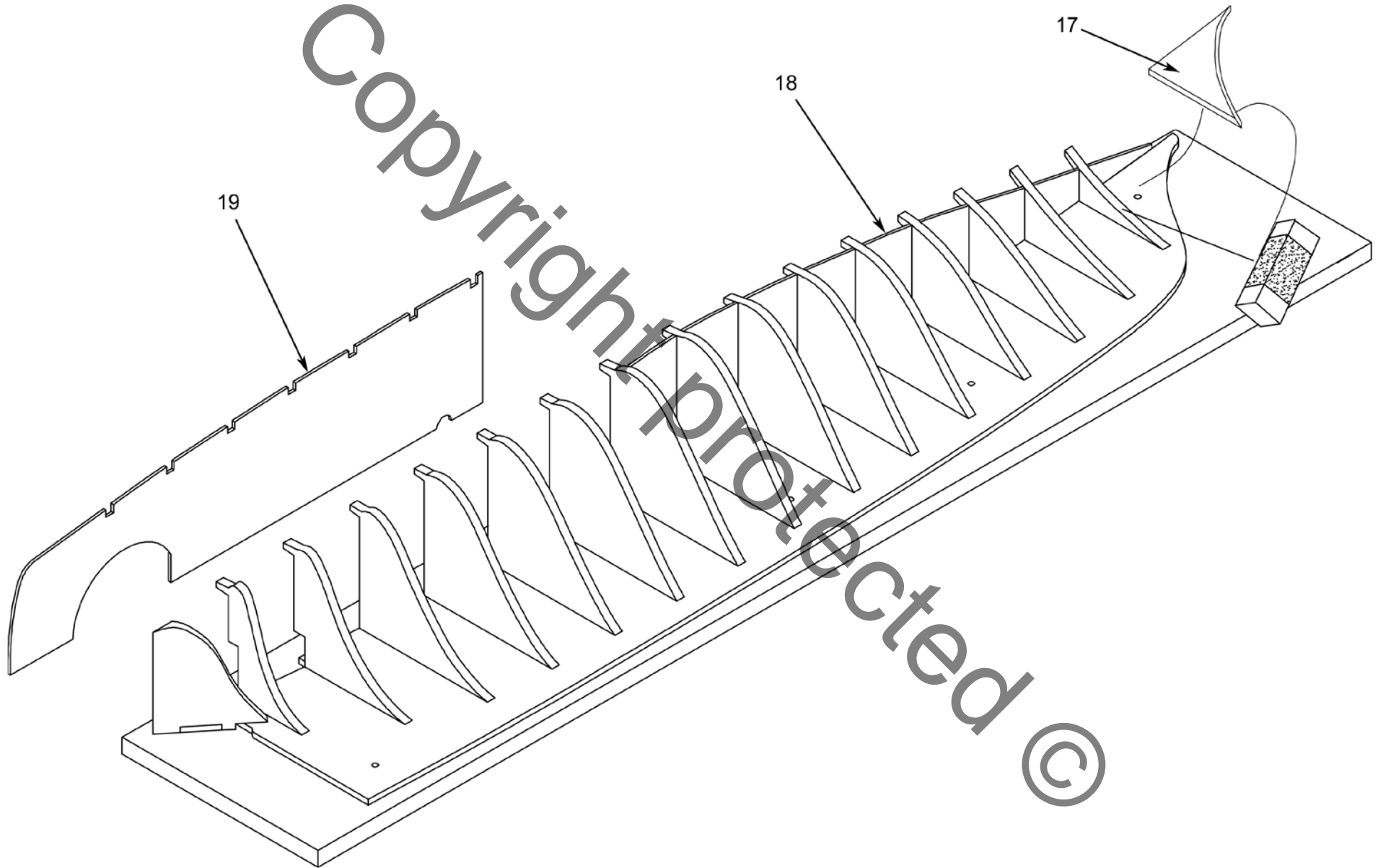

FIG.4

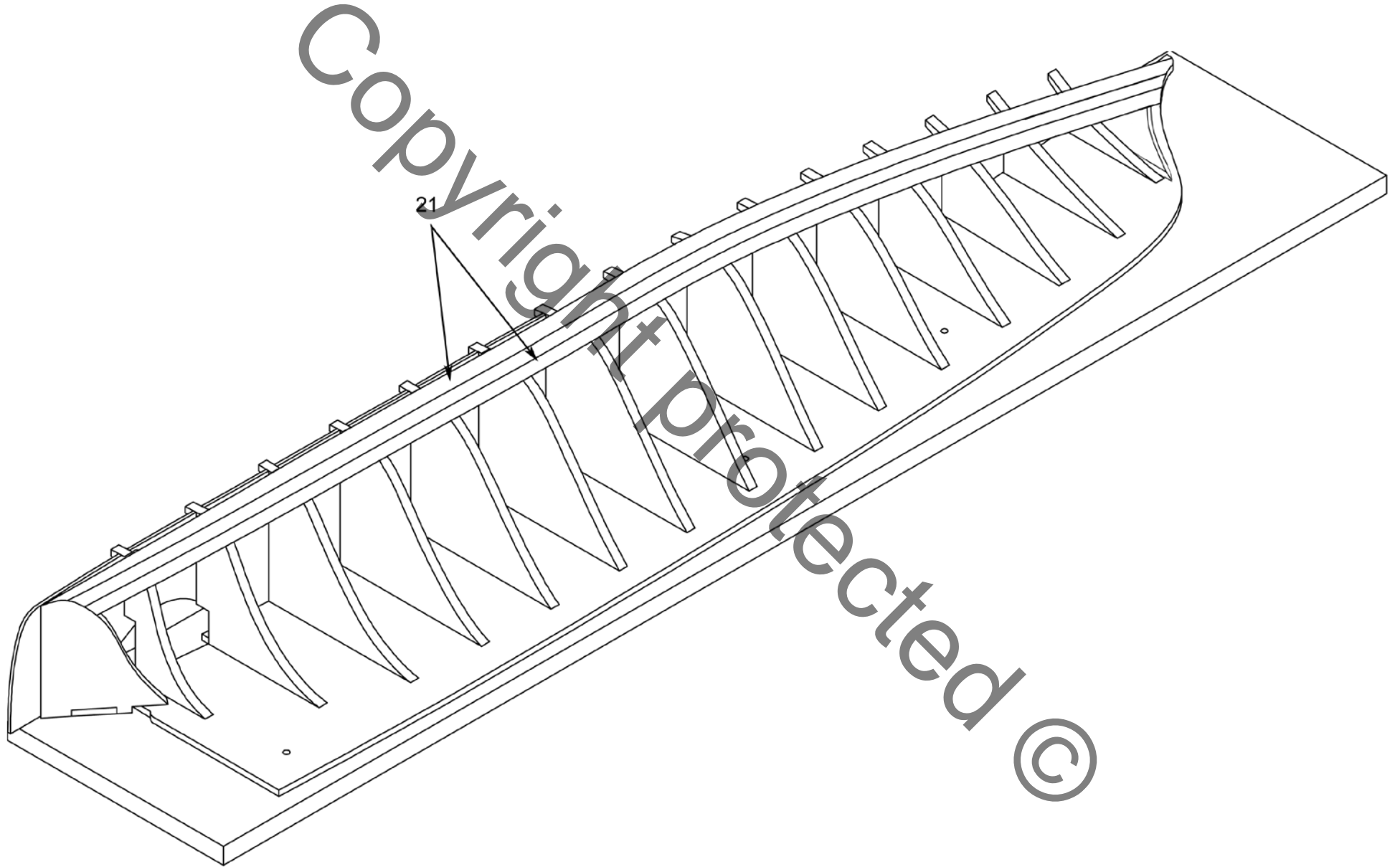

FIG.5

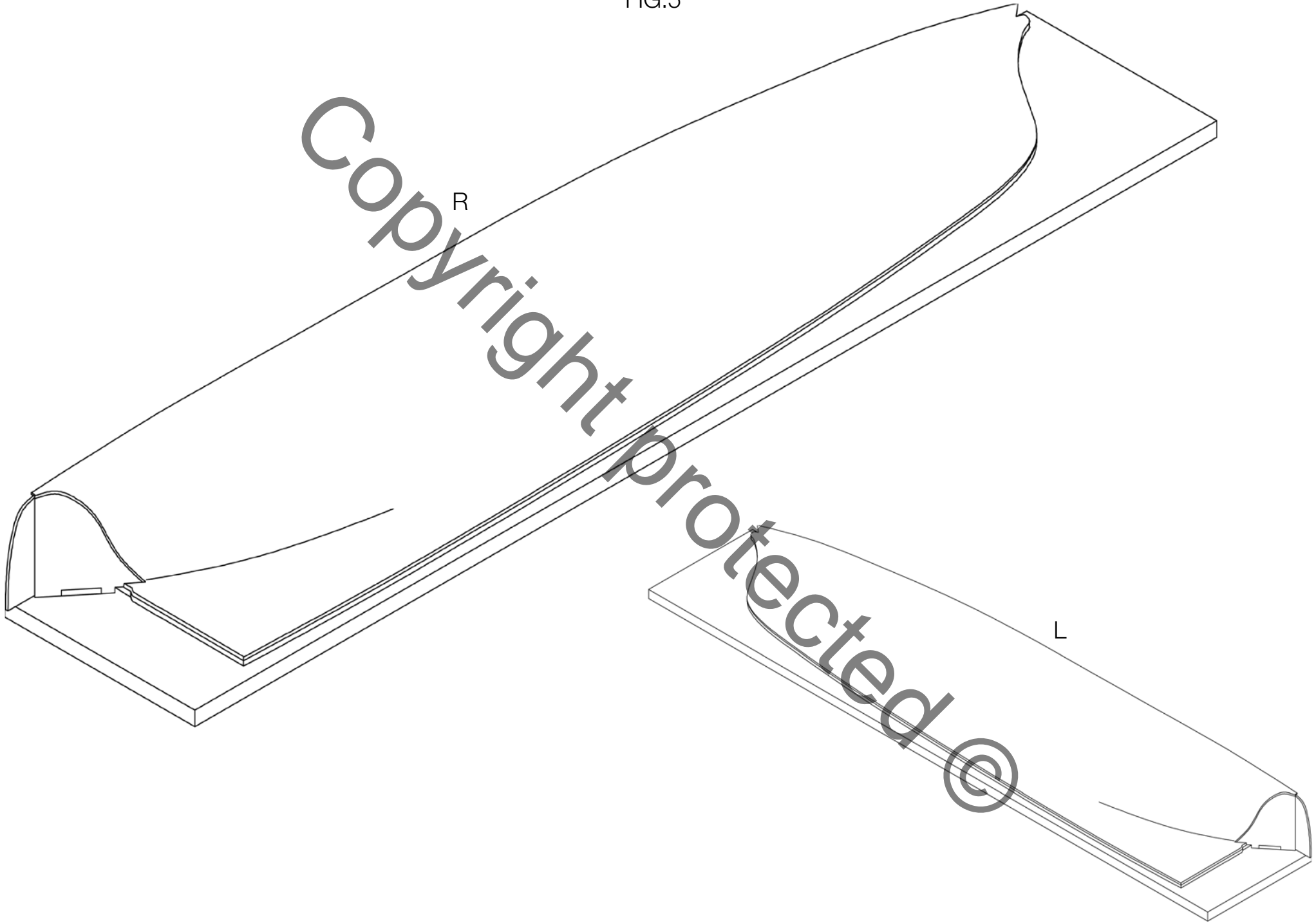

FIG.6

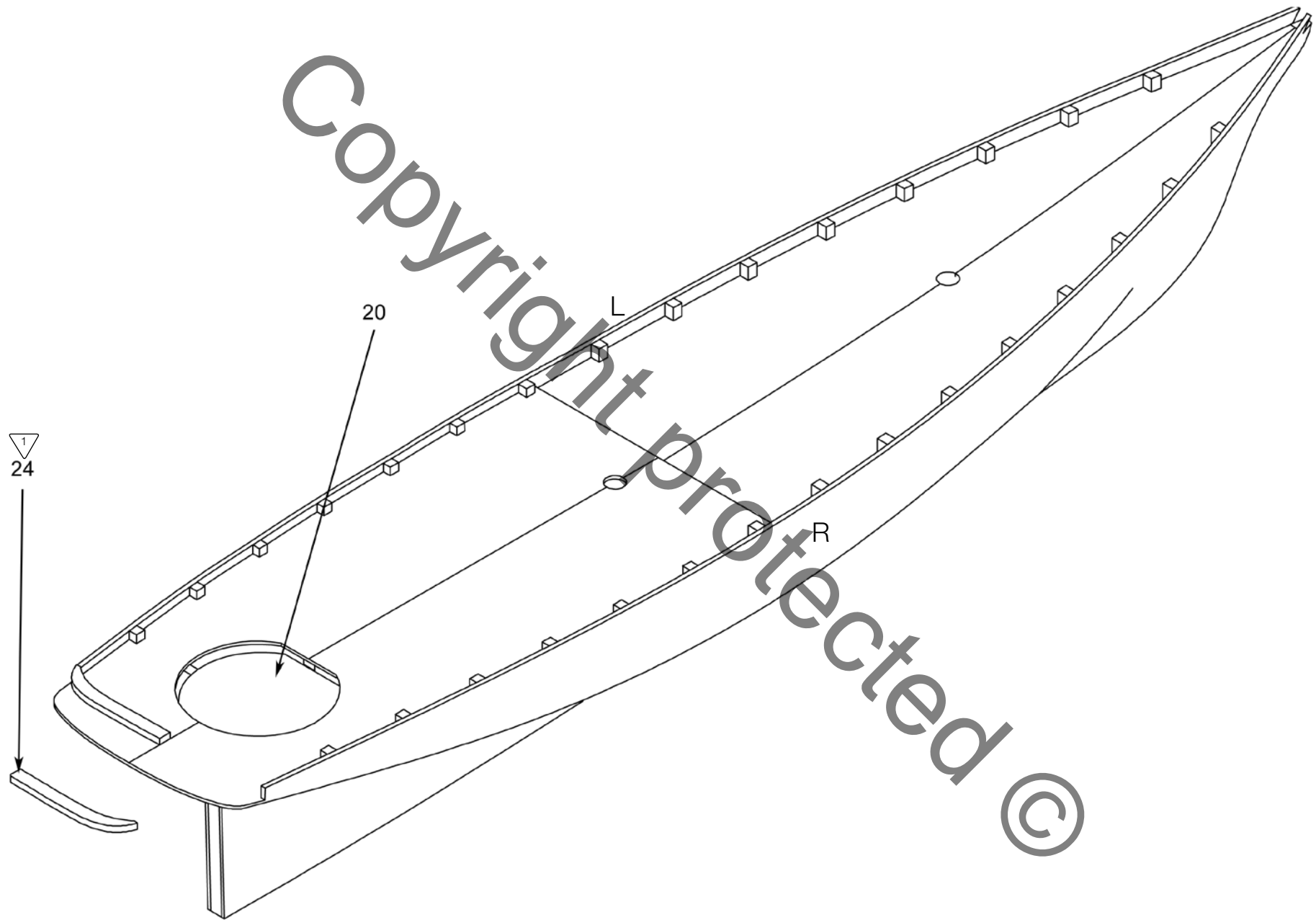

FIG.7

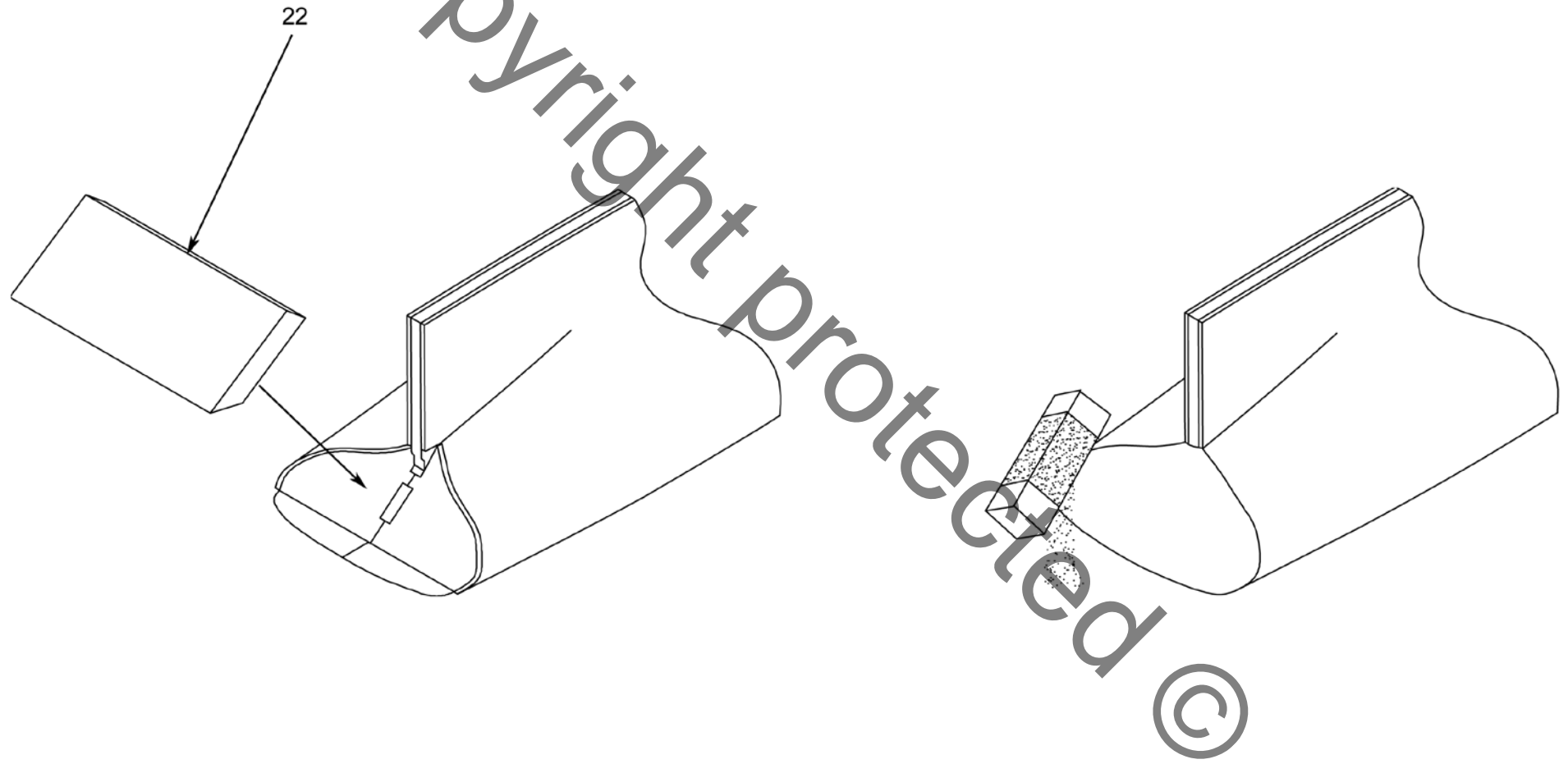

FIG.8

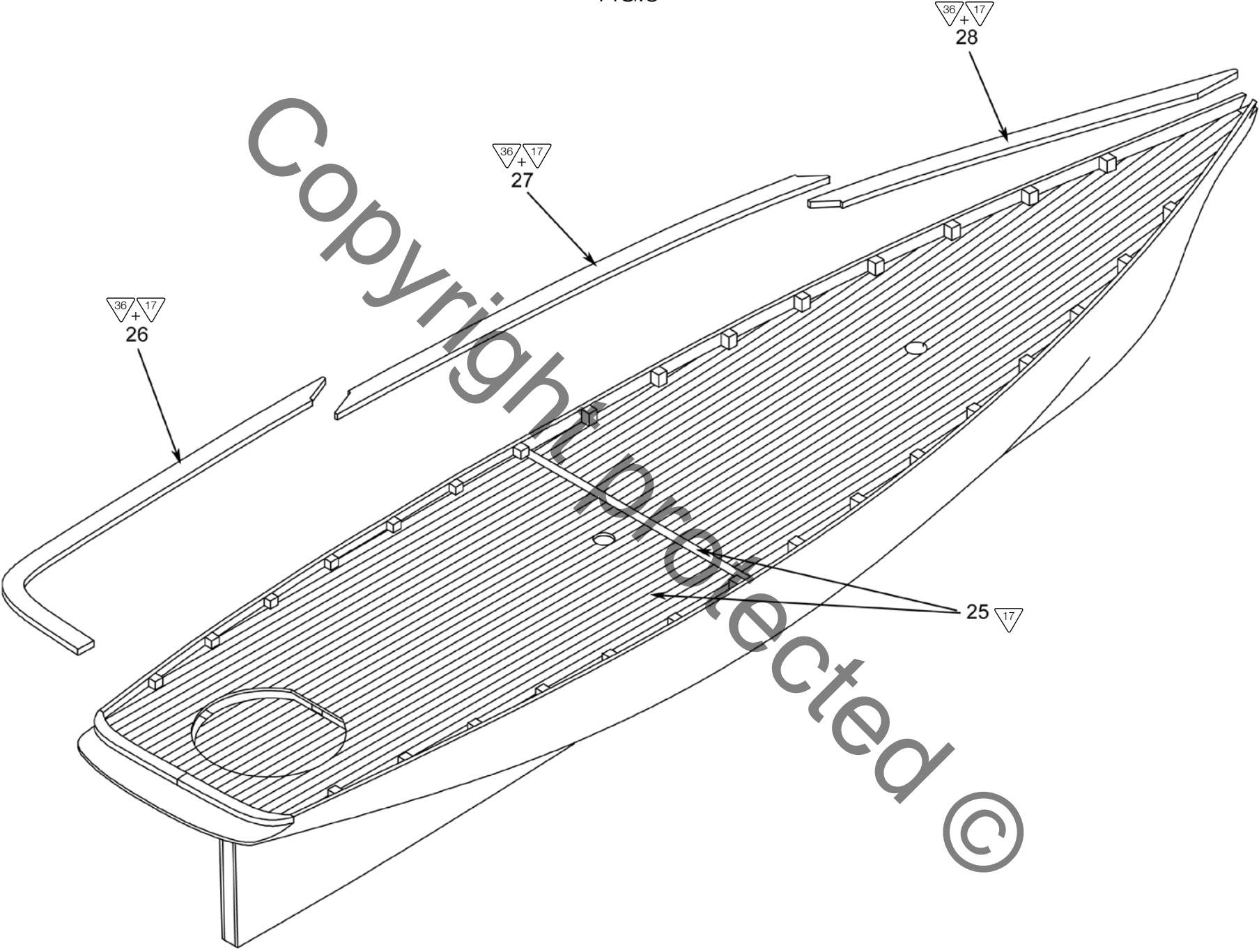

FIG.9

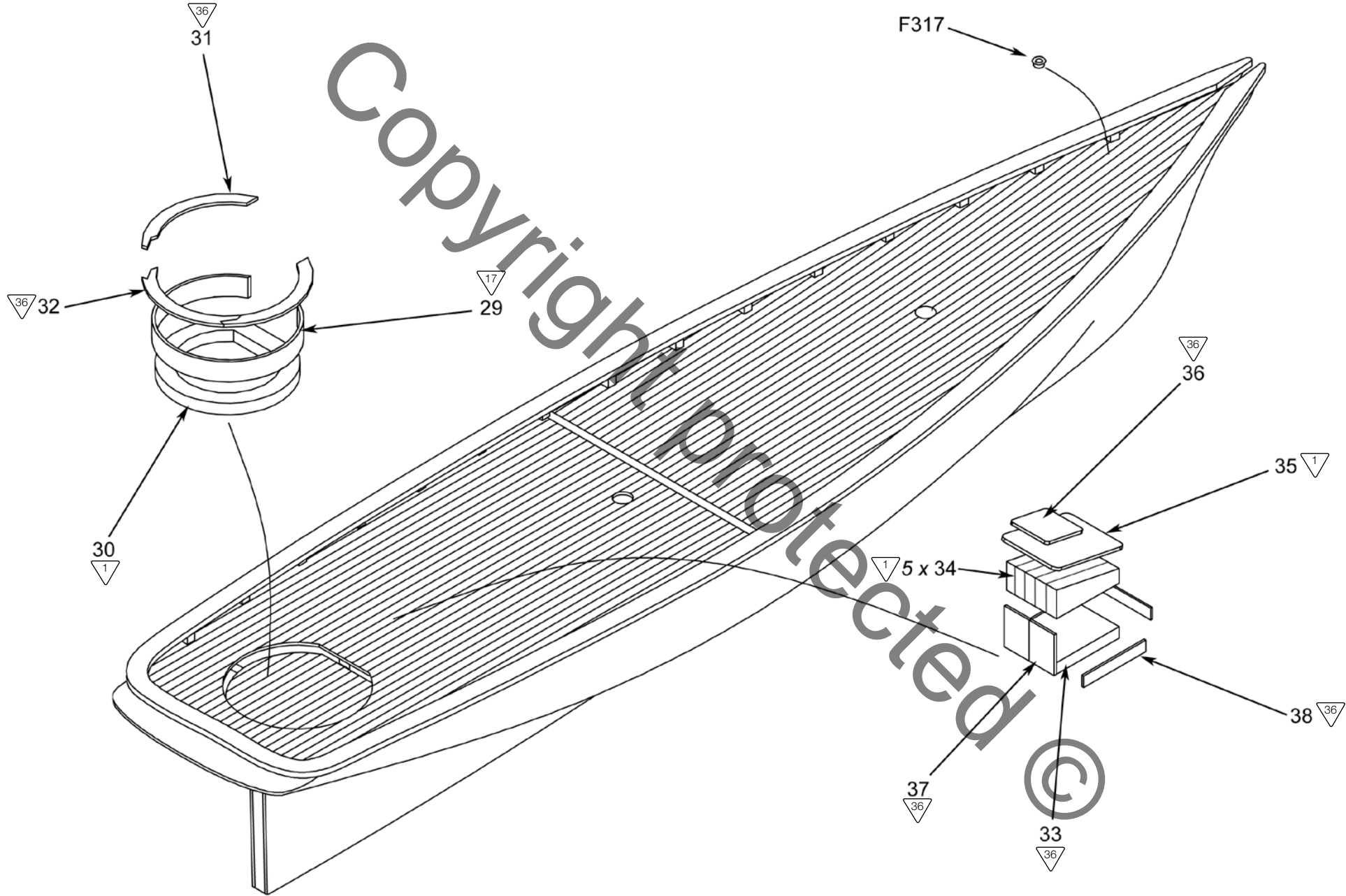

FIG.10

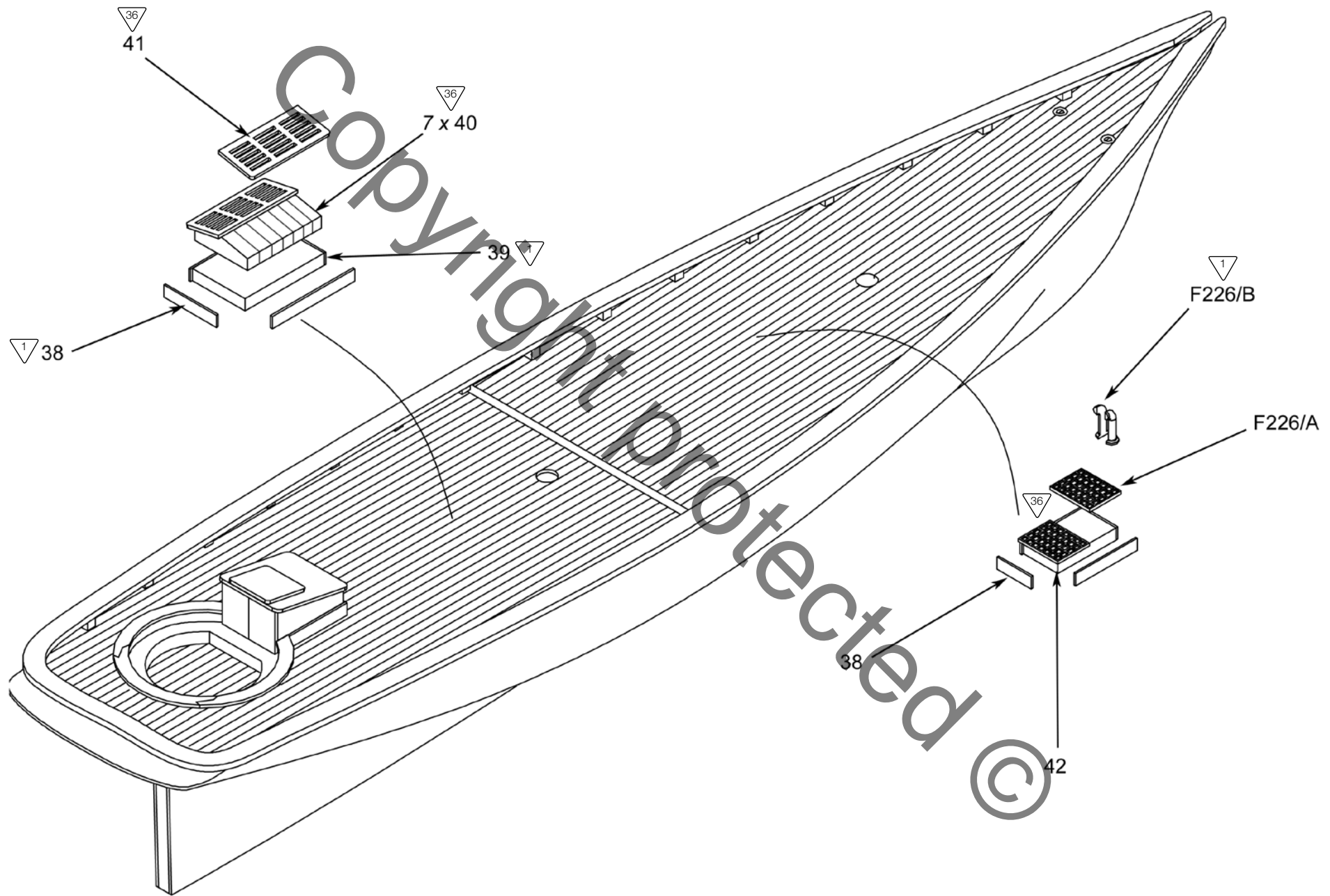

FIG.11

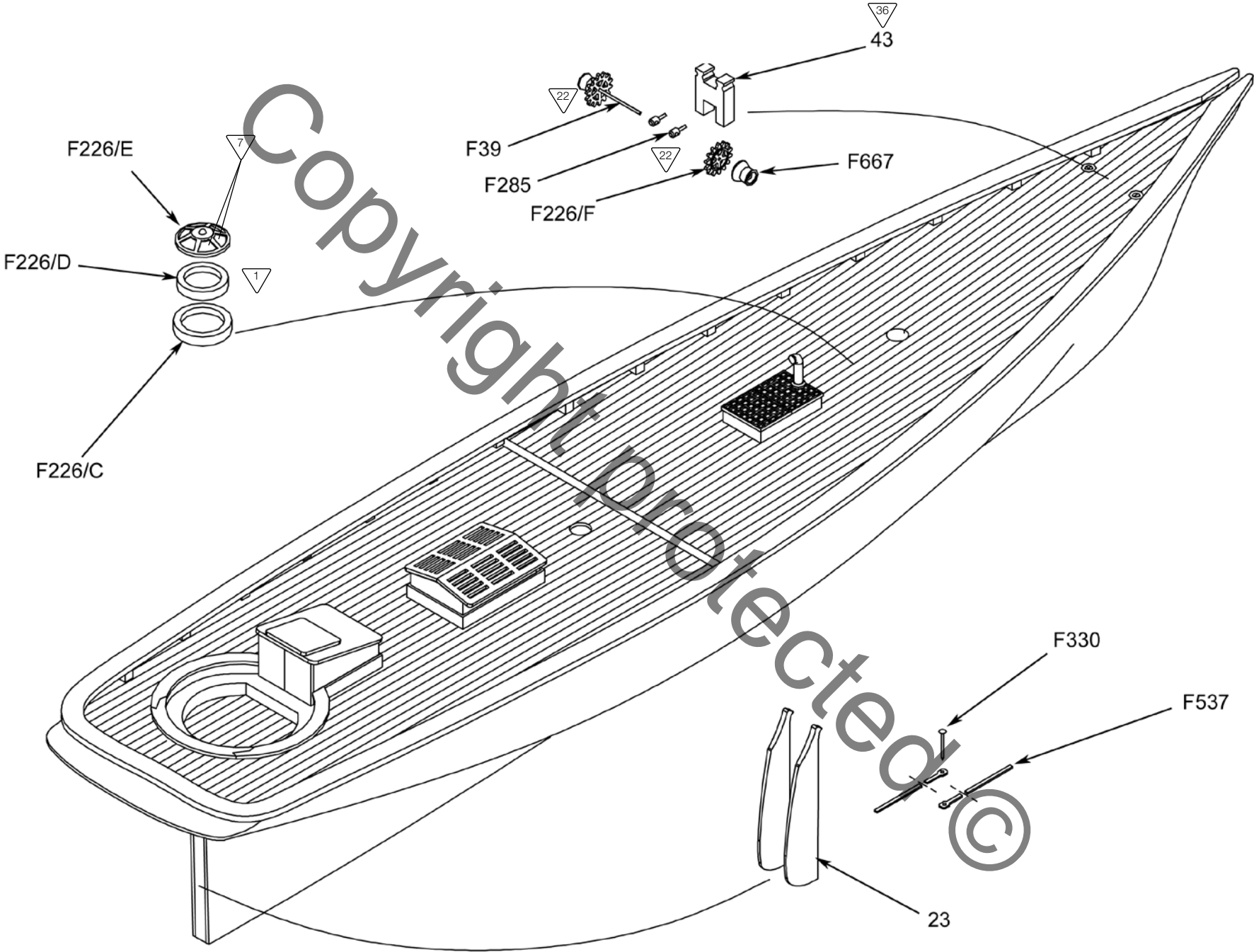

FIG.12

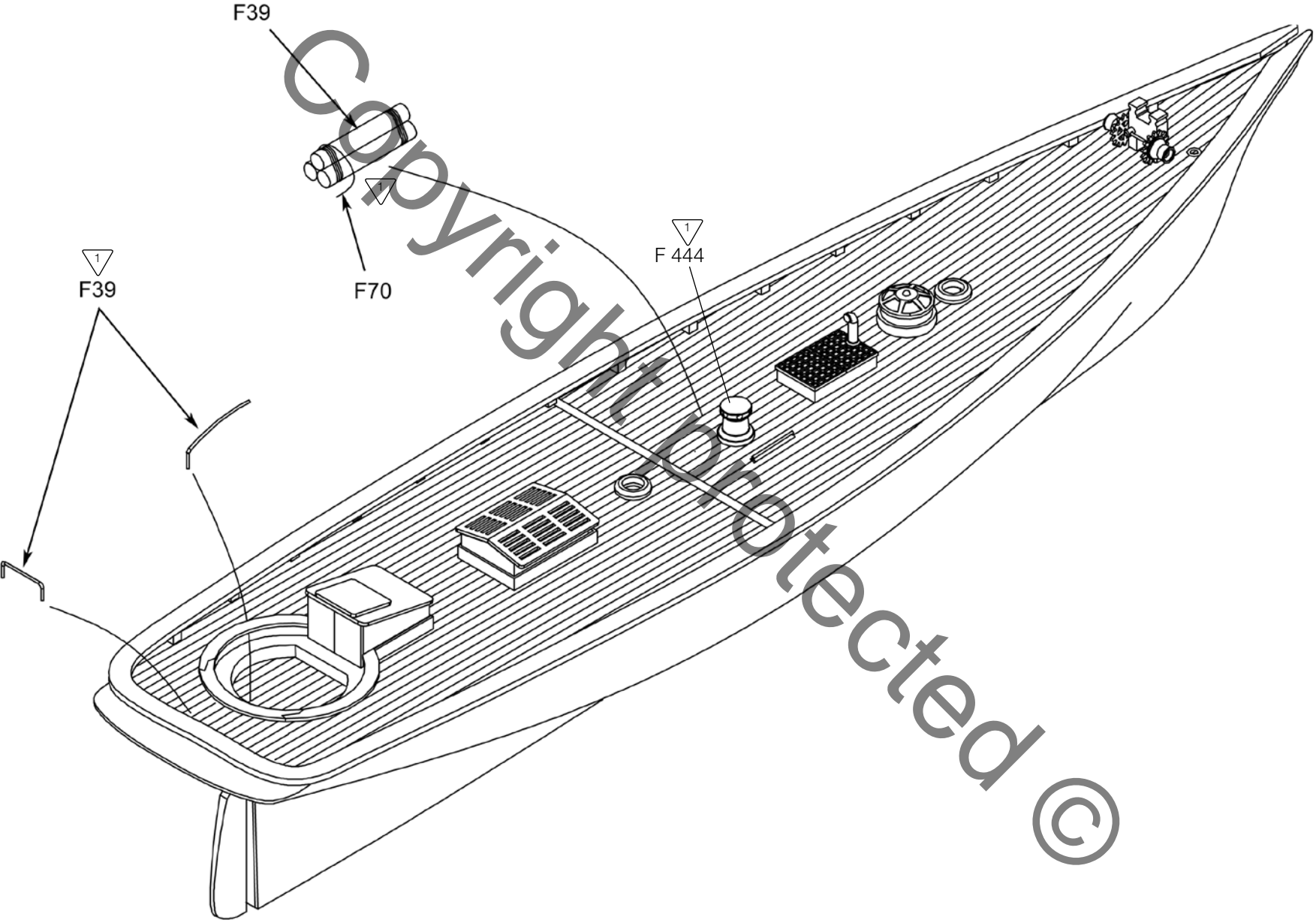

FIG.13

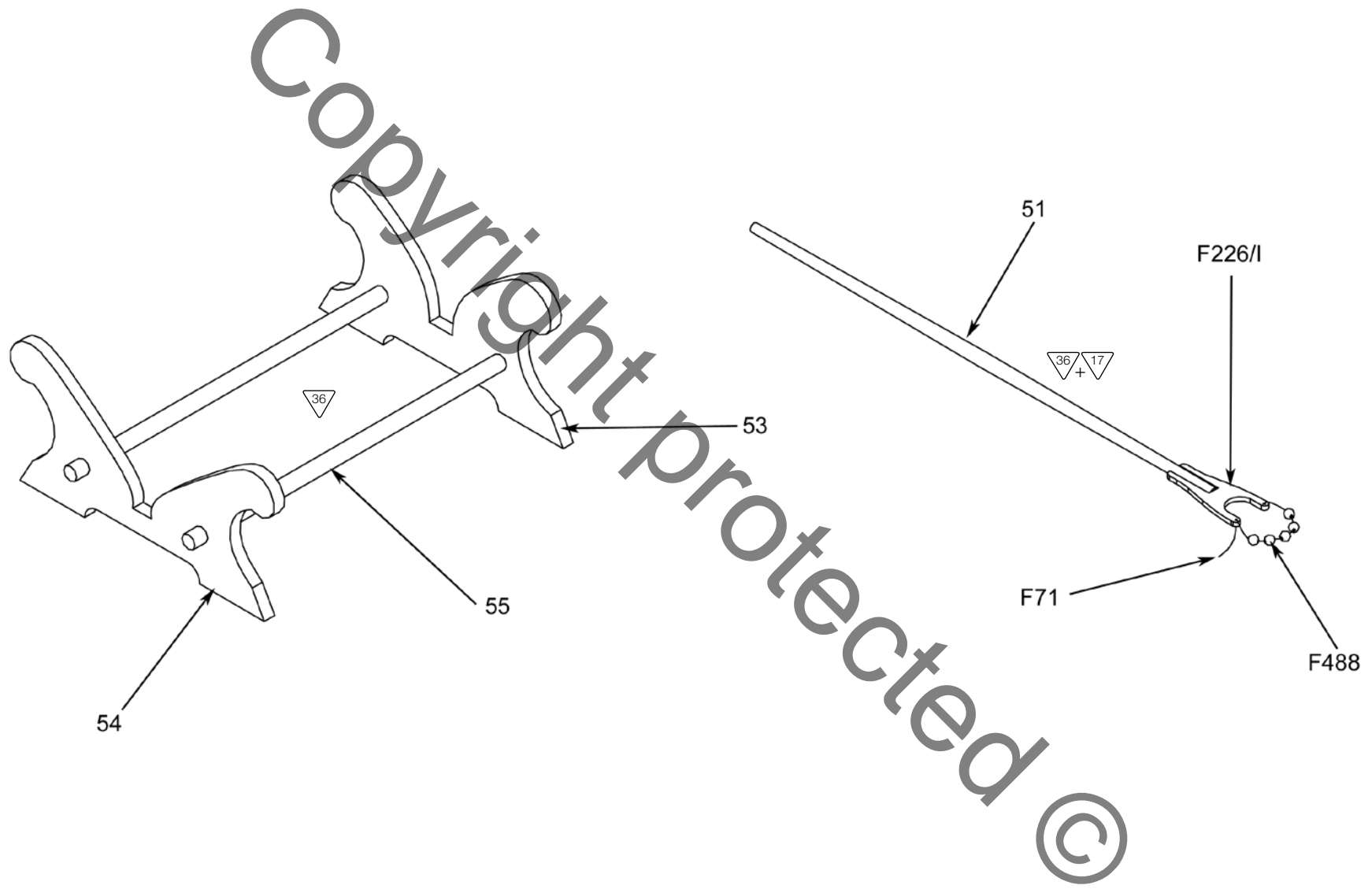

FIG.14

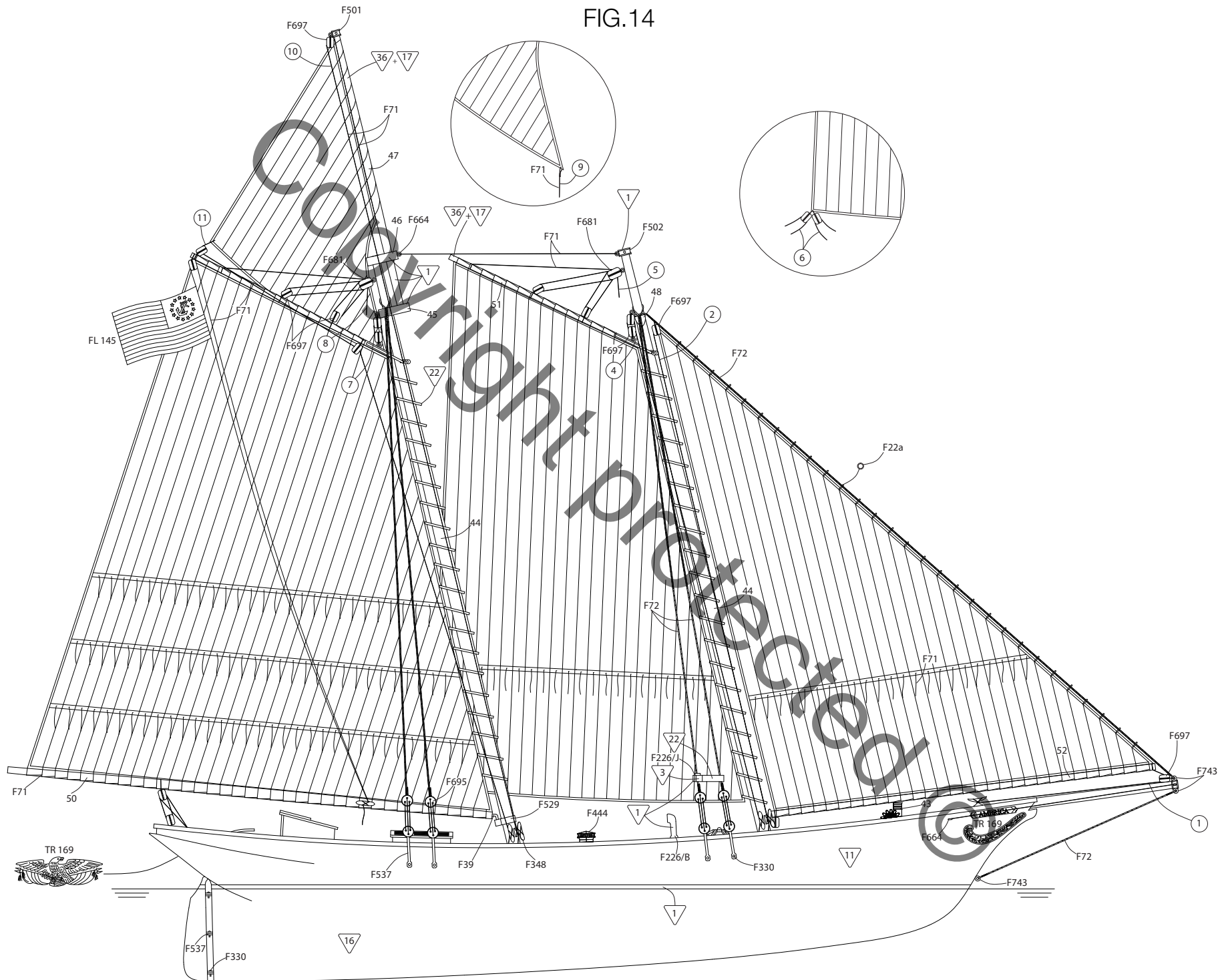
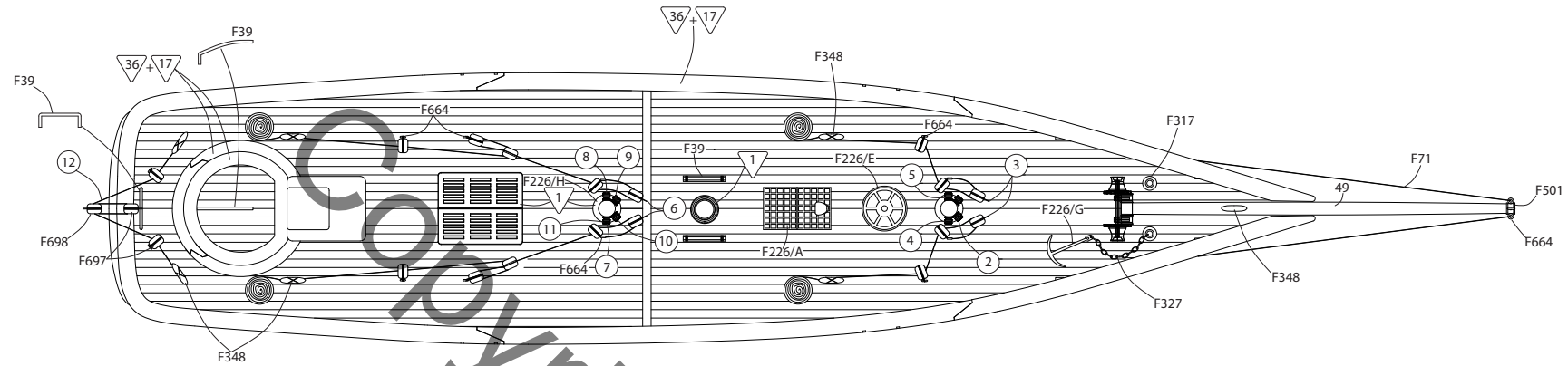

FIG.15



Symboler	○ = Rigningsnummer	Symbols	○ = Rigging No.	Zeichen	○ = Takel Nr.
	▽ = Farvenummer		▽ = Colour No.		▽ = Farben Nr.
Symboles	○ = Greement no.	Symbolen	○ = Tuigage Nr.	Símbolo	○ = Oparejo Nr.
	▽ = Couleur no.		▽ = Kleur Nr.		▽ = Color Nr.
Segno	○ = Attrezzatura N°	Simbolos	○ = Cordame n°		
	▽ = Colore N°		▽ = Cõr n°		

Til denne model er mahogni bejdse og farver med følgende numre nødvendige:

For this model is mahogany stain and colours with the following numbers should be used:

Für dieses Modell sind Mahagoni Beize und Farben mit den folgenden Nummern notwendig:

Pour ce modèle, le mordant et les couleurs avec les numéros suivants doivent être employées:

Voor dit model zijn kleuren met de volgende nummers nodig:

Para est modelo se necesitan mordiente et colores con los siguientes números:

Per questo modello occorrono inchiostro tinteggiatore "mogano" e colori con questi numeri:

Pinte o modelo com tintura cõr Mogno e as cõres sugeridas da Billing Boats:

Billing	1	=	White
Billing	3	=	Emerald
Billing	7	=	Sea Blue
Billing	9	=	Bright Red
Billing	11	=	Black
Billing	16	=	Gold
Billing	17	=	Clear Poly
Billing	22	=	Flat Black
Billing	36	=	Mahogani Stain

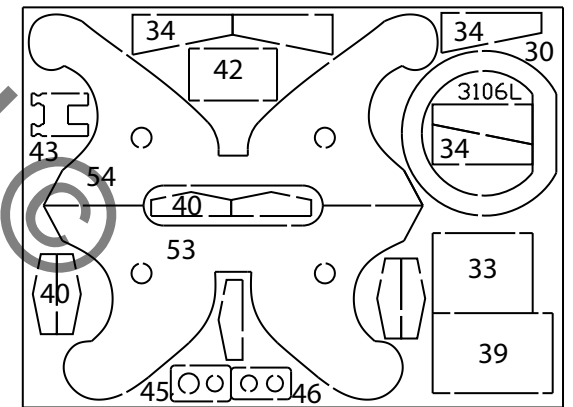
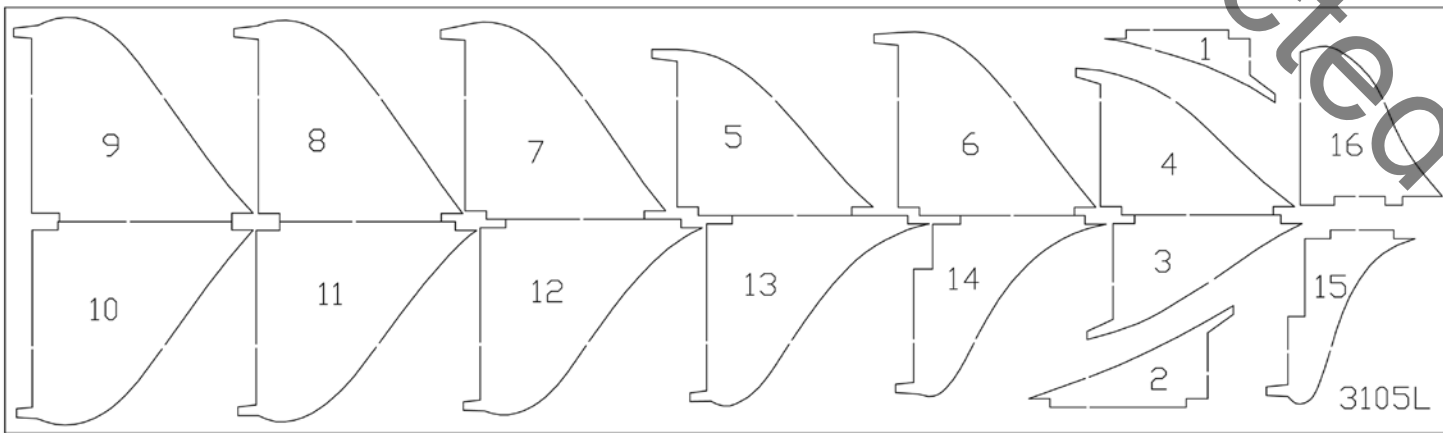
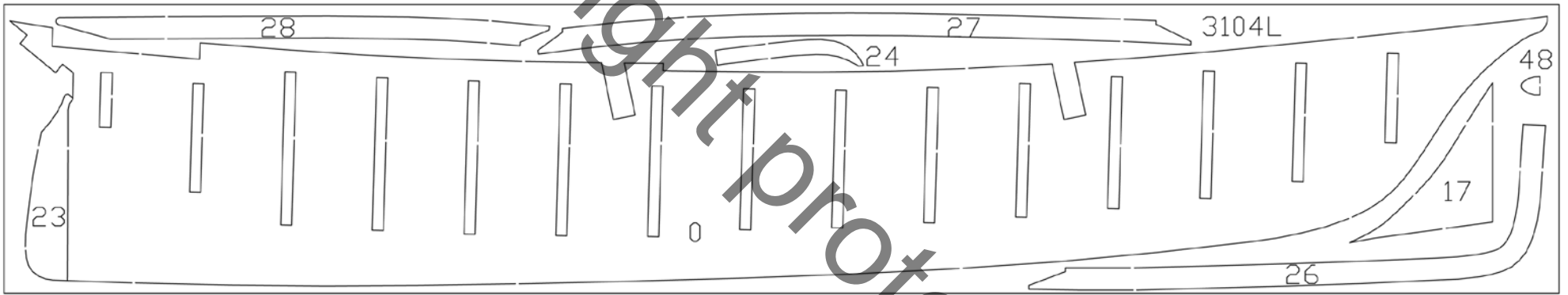
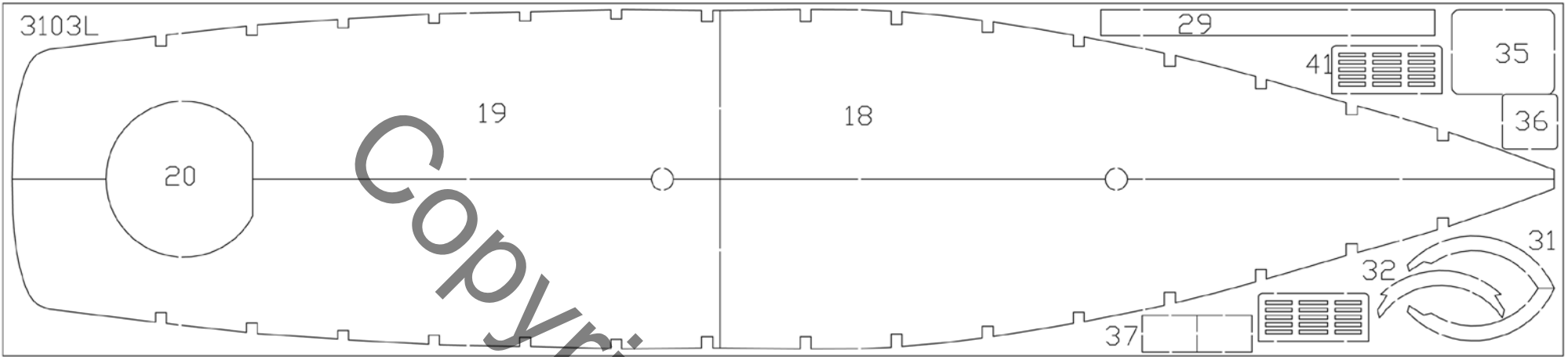

Table contents for "America" Art. No. 609

Pcs.	No.	Dimension	Material	DK	GB	D	F
1	0.0	430x80x6mm	MDF	Byggeplade	Slip	Helling	Cale
2	0	2 mm x-veneér	3104L	Køl	Keel	Kiel	Quilla
2	1	3 mm x-veneér	3105L	Spant	Frame	Spant	Couple
2	2	3 mm x-veneér	3105L	Spant	Frame	Spant	Couple
2	3	3 mm x-veneér	3105L	Spant	Frame	Spant	Couple
2	4	3 mm x-veneér	3105L	Spant	Frame	Spant	Couple
2	5	3 mm x-veneér	3105L	Spant	Frame	Spant	Couple
2	6	3 mm x-veneér	3105L	Spant	Frame	Spant	Couple
2	7	3 mm x-veneér	3105L	Spant	Frame	Spant	Couple
2	8	3 mm x-veneér	3105L	Spant	Frame	Spant	Couple
2	9	3 mm x-veneér	3105L	Spant	Frame	Spant	Couple
2	10	3 mm x-veneér	3105L	Spant	Frame	Spant	Couple
2	11	3 mm x-veneér	3105L	Spant	Frame	Spant	Couple
2	12	3 mm x-veneér	3105L	Spant	Frame	Spant	Couple
2	13	3 mm x-veneér	3105L	Spant	Frame	Spant	Couple
2	14	3 mm x-veneér	3105L	Spant	Frame	Spant	Couple
2	15	3 mm x-veneér	3105L	Spant	Frame	Spant	Couple
2	16	3 mm x-veneér	3105L	Spant	Frame	Spant	Couple
2	17	2 mm x-veneér	3104L	Faconstykke	Formed piece	Formteil	Pièce préfabriquée
2	18	1 mm x-veneér	3103L	Dæk	Deck	Deck	Pont
2	19	1 mm x-veneér	3103L	Dæk	Deck	Deck	Pont
1	20	1 mm x-veneér	3103L	Dæk	Deck	Deck	Pont
40	21	1,8x5x450 mm	Obechi	Liste	Strip	Leiste	Baguette
1	22	85x40x6mm	Balsa	Hækkloids	Stern Block	Heckklötze	Arrière poulie
2	23	2 mm x-veneér	3104L	Ror	Rudder	Ruder	Gouvernail
2	24	2 mm x-veneér	3104L	Faconstykke	Formed piece	Formteil	Pièce préfabriquée
30	25	0,7x3x450mm	Koto	Liste	Strip	Leiste	Baguette
2	26	2 mm x-veneér	3104L	Ræling	Rail	Reling	Plat bord
2	27	2 mm x-veneér	3104L	Ræling	Rail	Reling	Plat bord
2	28	2 mm x-veneér	3104L	Ræling	Rail	Reling	Plat bord
1	29	1 mm x-veneér	3103L	Karm	Coaming	Süß	Chambranle
1	30	4 mm x-veneér	3106L	Bænk	Bench	Bank	Banc
2	31	1 mm x-veneér	3103L	Karm	Coaming	Süß	Chambranle
1	32	1 mm x-veneér	3103L	Karm	Coaming	Süß	Chambranle
1	33	4 mm x-veneér	3106L	Nedgangsruf	Companion	Niedergangskappe	Ecoutille avant
5	34	4 mm x-veneér	3106L	Klods	Block	Block	Poulie
1	35	1 mm x-veneér	3103L	Luge	Hatch	Luke	Ecoutilles
1	36	1 mm x-veneér	3103L	Luge	Hatch	Luke	Ecoutilles
2	37	1 mm x-veneér	3103L	Dør	Door	Tür	Portes
1	38	0,7x4x450mm	Mahogany	Liste	Strip	Leiste	Baguette
1	39	4 mm x-veneér	3106L	Luge	Hatch	Luke	Ecoutilles
7	40	4 mm x-veneér	3106L	Skylight	Skylight	Oberlicht	Claire-voie
2	41	1 mm x-veneér	3103L	Skylight	Skylight	Oberlicht	Claire-voie
1	42	4 mm x-veneér	3106L	Luge	Hatch	Luke	Ecoutilles
1	43	4 mm x-veneér	3106L	Spil	Winch	Winde	Treuil
2	44	ø6x340mm	Ramin	Mast	Mast	Masten	Mat

1	45	4 mm x-veneér	3106L	Æselhoved	Cap	Eselhaupt	Chouquet
1	46	4 mm x-veneér	3106L	Æselhoved	Cap	Eselhaupt	Chouquet
1	47	ø4x180mm	Ramin	Mast	Mast	Masten	Mat
1	48	2 mm x-veneér	3104L	Kindbakke	Gripes	Kinnbacken	Jottereaux
1	49	ø4x180mm	Ramin	Bovspryd	Bowsprit	Bugsprit	Beaupré
1	50	ø5x250mm	Ramin	Bom	Boom	Baum	Bome
2	51	ø3x120mm	Ramin	Bom	Boom	Baum	Bome
1	52	ø3x180mm	Ramin	Rundstok	Round stick	Rundstab	Baguette ronde
1	53	4 mm x-veneér	3106L	Bedding	Slip	Ständer	Cale
1	54	4 mm x-veneér	3106L	Bedding	Slip	Ständer	Cale
2	55	ø5x130 mm	Ramin	Rundstok	Round stick	Rundstab	Baguette ronde
1	56		TR.169	Transfer	Transfer	Abziehbild	Décal
1	57		FL.145	Flag	Flag	Flaggen	Voil

Table contents for fittingkit "America"

Pcs.	No.	Dimension		DK	GB	D	F
1	F22a	0,5mm	Kobber	Kobbertråd	Copper wire	Kupferdraht	Fil de cuivre
1	F39	ø1x250 mm	Ms	Messingtråd	Brass wire	Messingdraht	Fils de laiton
1	F70	3M		Tråd	Rigging thread	Takelgarn	Fil de gréement
1	F71	30M		Tråd	Rigging thread	Takelgarn	Fil de gréement
1	F72	3M		Tråd	Rigging thread	Takelgarn	Fil de gréement
1	F226			Plaststøb	Plaststeeb	Plastikbeschlag	Garniture en plastic
1	F227			Plaststøb	Plaststeeb	Plastikbeschlag	Garniture en plastic
2	F285	5,5mm	Ms	Øjebolt	Eye-bolt	Augbolzen	Pitons
2	F317	ø4mm	Ms	Klyds	Fairlead	Verklöklüse	Chaumard
1	F327	100 mm	Kobber	Kæde	Chain	Kette	Cahine
21	F330	10mm	Ms	Søm	Pins	Nägel	Clous
16	F348	9mm	Ps	Klampe	Cleat	Klampen	Taquets
1	F444	ø10mm	Ms	Kapstan	Capstan	Kapstan	Cabestan
10	F488	ø3mm	Plastic	Ragperle	Perls	Rackperlen	Perle
2	F501	ø4mm	Ms	Mastering	Mast hoop	Mastringe	Cercle de mat
1	F502	ø5mm	Ms	Mastering	Mast hoop	Mastringe	Cercle de mat
1	F529	ø6mm	Ms	Mastering	Mast hoop	Mastringe	Cercle de mat
14	F537	25mm	Ms	Røstjern	Chain plates	Rüsteisen	Cadénes
29	F664	11mm	Kobber	Øjebolt	Eye-bolt	Augbolzen	Pitons
2	F667	ø6mm	Ms	Spilkop	Warping drum	Spillkopf	Poupée
2	F681	7,5mm	Træ	Blok	Block	Blok	Poulies
16	F695	ø5mm	Træ	Jomfru	Dead eye	Juffern	Caps de mouton
29	F697	5mm	Træ	Blok	Block	Blok	Poulies
1	F698	5mm	Træ	Blok	Block	Blok	Poulies
3	F743	9mm	Ms	Øjebolt	Eye-bolt	Augbolzen	Pitons

Table contents for "America" Art. No. 609

Pcs.	No.	Dimension	Material	NL	E	I	P
1	0.0	430x80x6mm	MDF	Standaard	Grada	Asse da mantaggio (scalo)	Carreira
2	0	2 mm x-veneér	3104L	Kiel	Quilla	Chiglia	Quilha
2	1	3 mm x-veneér	3105L	Spanten	Cuaderna	Ordinata	Armacão
2	2	3 mm x-veneér	3105L	Spanten	Cuaderna	Ordinata	Armacão
2	3	3 mm x-veneér	3105L	Spanten	Cuaderna	Ordinata	Armacão
2	4	3 mm x-veneér	3105L	Spanten	Cuaderna	Ordinata	Armacão
2	5	3 mm x-veneér	3105L	Spanten	Cuaderna	Ordinata	Armacão
2	6	3 mm x-veneér	3105L	Spanten	Cuaderna	Ordinata	Armacão
2	7	3 mm x-veneér	3105L	Spanten	Cuaderna	Ordinata	Armacão
2	8	3 mm x-veneér	3105L	Spanten	Cuaderna	Ordinata	Armacão
2	9	3 mm x-veneér	3105L	Spanten	Cuaderna	Ordinata	Armacão
2	10	3 mm x-veneér	3105L	Spanten	Cuaderna	Ordinata	Armacão
2	11	3 mm x-veneér	3105L	Spanten	Cuaderna	Ordinata	Armacão
2	12	3 mm x-veneér	3105L	Spanten	Cuaderna	Ordinata	Armacão
2	13	3 mm x-veneér	3105L	Spanten	Cuaderna	Ordinata	Armacão
2	14	3 mm x-veneér	3105L	Spanten	Cuaderna	Ordinata	Armacão
2	15	3 mm x-veneér	3105L	Spanten	Cuaderna	Ordinata	Armacão
2	16	3 mm x-veneér	3105L	Spanten	Cuaderna	Ordinata	Armacão
2	17	2 mm x-veneér	3104L	Gevormd deel	Plagilla	Pezzo prefabbricato	Amurada de popa
2	18	1 mm x-veneér	3103L	Dek	Cubierta	Ponte	Deck
2	19	1 mm x-veneér	3103L	Dek	Cubierta	Ponte	Deck
1	20	1 mm x-veneér	3103L	Dek	Cubierta	Ponte	Deck
40	21	1,8x5x450 mm	Obechi	Strip	Listón	Listello	Tira
1	22	85x40x6mm	Balsa	Achtersteven blokken	Taco de popa	Blocco di poppa	Bloco da popa
2	23	2 mm x-veneér	3104L	Roer	Timón	Timone	Leme
2	24	2 mm x-veneér	3104L	Gevormd deel	Plantilla	Pezzo prefabbricato	Amurada de popa
30	25	0,7x3x450mm	Koto	Strip	Listón	Listello	Tira
2	26	2 mm x-veneér	3104L	Reling	Borda	Parapetto	Amurada de popa
2	27	2 mm x-veneér	3104L	Reling	Borda	Parapetto	Amurada de popa
2	28	2 mm x-veneér	3104L	Reling	Borda	Parapetto	Amurada de popa
1	29	1 mm x-veneér	3103L	Lijst	Masco	Battente	Moldura
1	30	4 mm x-veneér	3106L	Bank	Banco	Banca	Banco
2	31	1 mm x-veneér	3103L	Lijst	Masco	Battente	Moldura
1	32	1 mm x-veneér	3103L	Lijst	Masco	Battente	Moldura
1	33	4 mm x-veneér	3106L	Trapafgang	Bajada	Scaletta boccaporto	Convés
5	34	4 mm x-veneér	3106L	Blok	Bloque	Blocco	Blocos
1	35	1 mm x-veneér	3103L	Luikdeel	Escotilla	Boccaporto	Escotilha
1	36	1 mm x-veneér	3103L	Luikdeel	Escotilla	Boccaporto	Escotilha
2	37	1 mm x-veneér	3103L	Deur	Puerta	Portelli	Portas
1	38	0,7x4x450mm	Mahogany	Strip	Listón	Listello	Tira
1	39	4 mm x-veneér	3106L	Luikdeel	Escotilla	Boccaporto	Escotilha
7	40	4 mm x-veneér	3106L	Bovenlicht	Lumbrera	Osteriggio	Clarabóia de proa
2	41	1 mm x-veneér	3103L	Bovenlicht	Lumbrera	Osteriggio	Clarabóia de proa
1	42	4 mm x-veneér	3106L	Luikdeel	Escotilla	Boccaporto	Escotilha
1	43	4 mm x-veneér	3106L	Winch	Chigre	Vericello	Guincho
2	44	ø6x340mm	Ramin	Masten	Palo	Albero	Mastros

1	45	4 mm x-veneér	3106L	Ezelshoofd	Herraje de juntapalos	Testa de moro	Pega
1	46	4 mm x-veneér	3106L	Ezelshoofd	Herraje de juntapalos	Testa de moro	Pega
1	47	ø4x180mm	Ramin	Masten	Palo	Albero	Mastros
1	48	2 mm x-veneér	3104L	Hulpstukken vor kiel	Mandíbula	Ganasce	Juncão
1	49	ø4x180mm	Ramin	Boegspriet	Bauprés	Bompresso	Gurupés
1	50	ø5x250mm	Ramin	Boom	Botavara	Asta	Icador de rede
2	51	ø3x120mm	Ramin	Boom	Botavara	Asta	Icador de rede
1	52	ø3x180mm	Ramin	Rondhout	Barra redonda	Tondino (listello)	Bastão cilíndrico
1	53	4 mm x-veneér	3106L	Standaard	Grada	Supporto	Apoio
1	54	4 mm x-veneér	3106L	Standaard	Grada	Supporto	Apoio
2	55	ø5x130 mm	Ramin	Rondhout	Barra redonda	Tondino (listello)	Bastão cilíndrico
1	56		TR.169	Transfer	Transfer	Decalcomanie	Transfer
1	57		FL.145	Vlag	Bandera	Bandiere	Bandeira

Table contents for fittingkit "America"

Pcs.	No.	Dimension		NL	E	I	P
1	F22a	0,5mm	Kobber	Koperdraat	Alambre de cabre	Filo in rame	Fio de Cobre
1	F39	ø1x250 mm	Ms	Messingdraad	Hilo de latón	Filo in ottone	Fio de latão
1	F70	3M		Takelgaren	Hilo de oparejo	Cordame manovra	Linha de cordame
1	F71	30M		Takelgaren	Hilo de oparejo	Cordame manovra	Linha de cordame
1	F72	3M		Takelgaren	Hilo de oparejo	Cordame manovra	Linha de cordame
1	F226			Plastikbeslag	Herrajes de plástico	Accessorio in plastica	Fittings de plástico
1	F227			Plastikbeslag	Herrajes de plástico	Accessorio in plastica	Fittings de plástico
2	F285	5,5mm	Ms	Patrijspoort	Pernos de cánamo	Bullone ad occhio	Ferrolho
2	F317	ø4mm	Ms	Verhaalklamp	Bocina	Rinforzo	Tubo do escovém
1	F327	100 mm	Kobber	Ketting	Cadena	Catena	Corrente
21	F330	10mm	Ms	Spijkertjes	Clavo	Chiodi	Cravelhas
16	F348	9mm	Ps	Kikkers	Cornamusas	Galloccia	Cunho/castanha
1	F444	ø10mm	Ms	Winsch	Cabrestante	Argano	Cabrestante
10	F488	ø3mm	Plastic	Rakkralen	Perla	Perla	Pérolas
2	F501	ø4mm	Ms	Hoepel	Zunzho	Anello dell'albero	Arco do mastro
1	F502	ø5mm	Ms	Hoepel	Zunzho	Anello dell'albero	Arco do mastro
1	F529	ø6mm	Ms	Hoepel	Zunzho	Anello dell'albero	Arco do mastro
14	F537	25mm	Ms	Puttings	Cadenote	Landra	Placas das correntes
29	F664	11mm	Kobber	Patrijspoort	Pernos de cánamo	Bullone ad occhio	Ferrolho
2	F667	ø6mm	Ms	Verhaalkop	Tambor	Testa argano	Tambor de espia
2	F681	7,5mm	Træ	Blok	Tornillo	Blocco	Polias
16	F695	ø5mm	Træ	Jufferblokken	Virgines	Testa de montone	Bigota
29	F697	5mm	Træ	Blok	Tornillo	Blocco	Polias
1	F698	5mm	Træ	Blok	Tornillo	Blocco	Polias
3	F743	9mm	Ms	Patrijspoort	Pernos de cánamo	Bullone ad occhio	Ferrolho

